



38 – 60V_{IN}, 160W ZVS Buck-Boost Regulator

Product Description

The PI3755-02 is a high-efficiency, wide-input-range DC-DC ZVS Buck-Boost regulator. This high-density module integrates controller, power switches and support components. The integration of a high-performance Zero-Voltage Switching (ZVS) topology within the PI3755-02 increases point-of-load performance providing best-in-class power efficiency.

The PI3755-02 requires an externally applied 5V bias to the VDR input, an external inductor, resistive divider and minimal capacitors to form a complete DC-DC switching mode buck-boost regulator.

The ZVS architecture also enables high frequency operation while minimizing switching losses and maximizing efficiency. The high switching frequency operation reduces the size of the external filtering components, improves power density and enables very fast dynamic response to line and load transients. The PI3755-02 sustains high switching frequency up to the rated input voltage without sacrificing efficiency and supports large conversion ratios.



PI3755-02-LGIZ



PI3755-02-LGIG

Features & Benefits

- 98% efficiency at 1.5MHz F_{SW}
- Wide input voltage range of 38 – 60V
- Wide output voltage range of 28 – 54V
- 160W continuous output power
- Power density exceeding 6,400W/in³
- Fast transient response in VRM 12.X applications
- Light-load mode <200mW no-load power dissipation
- VTM compatibility mode
- User configurable differential amplifier
- Input / Output Over / Undervoltage Protection
- Overtemperature protection
- Fast and slow current limits
- –40 to 125°C operating range (T_J)

Applications

- VR12.X Factorized Power Solution (when coupled with a VTM™ device)
- Computing, Communications, DDR Memory
- 48V to PoL Power Solutions

Package Information

- 10 x 10 x 2.56mm Land Grid Array Module

Typical Application

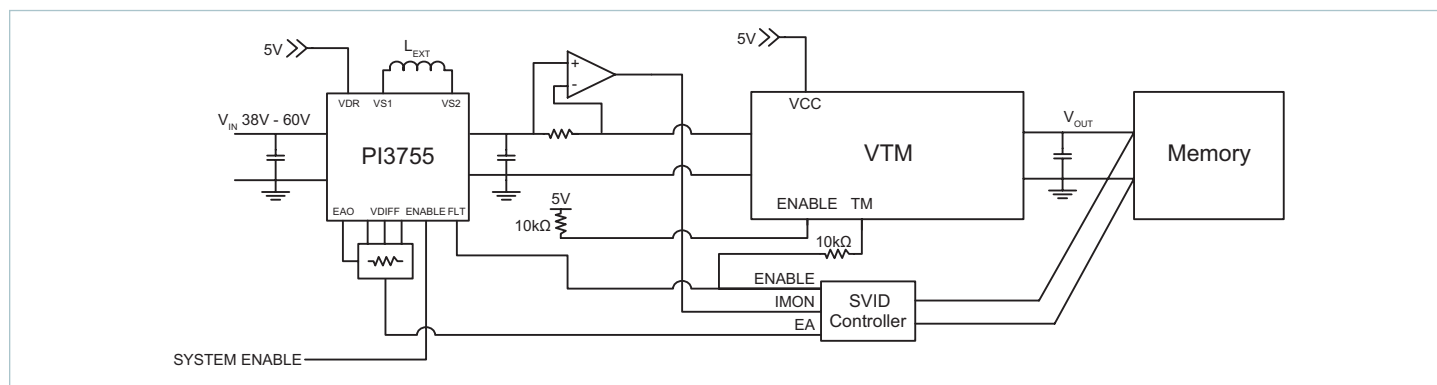

Applications diagram for use within a Factorized Power, VR12.5 design

Note: Product images may not highlight current product markings and cosmetic features.

Package Pinout

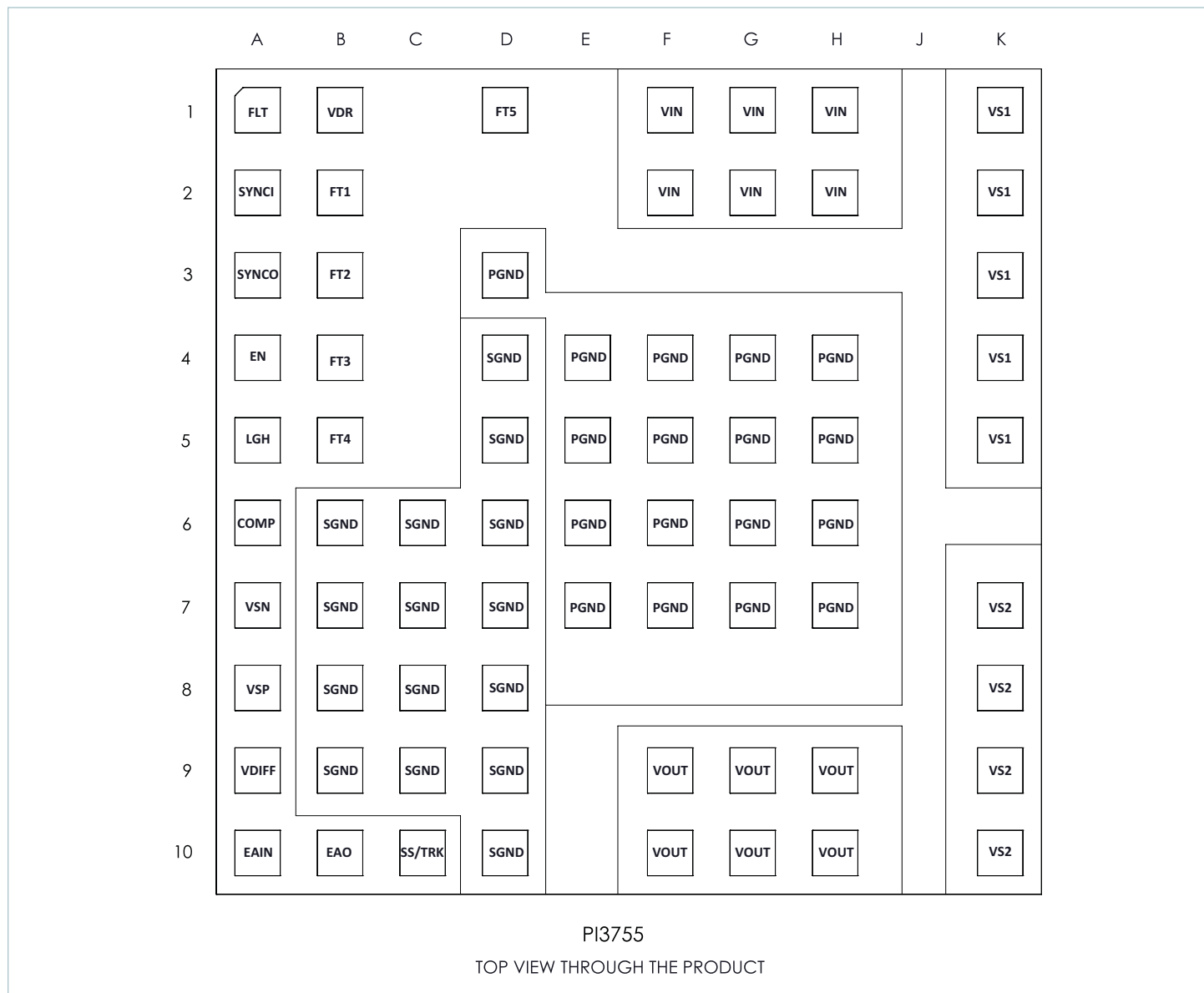

Large Pin Blocks

Pin Block Name	Group of pins
VIN	F1 – 2, G1 – 2, H1 – 2
VS1	K1 – 5
PGND	D3, E4 – 7, F4 – 7, G4 – 7, H4 – 7
VS2	K7 – 10
VOUT	F9 – 10, G9 – 10, H9 – 10
SGND	B6 – 9, C6 – 9, D4 – 10

Vicor's comprehensive line of power solutions includes high density AC-DC and DC-DC modules and accessory components, fully configurable AC-DC and DC-DC power supplies, and complete custom power systems.

Information furnished by Vicor is believed to be accurate and reliable. However, no responsibility is assumed by Vicor for its use. Vicor makes no representations or warranties with respect to the accuracy or completeness of the contents of this publication. Vicor reserves the right to make changes to any products, specifications, and product descriptions at any time without notice. Information published by Vicor has been checked and is believed to be accurate at the time it was printed; however, Vicor assumes no responsibility for inaccuracies. Testing and other quality controls are used to the extent Vicor deems necessary to support Vicor's product warranty. Except where mandated by government requirements, testing of all parameters of each product is not necessarily performed.

Specifications are subject to change without notice.

Visit <https://www.vicorpower.com/all-products/dc-dc/non-isolated-regulated/data-center-prm-and-vtm> for the latest product information.

Vicor's Standard Terms and Conditions and Product Warranty

All sales are subject to Vicor's Standard Terms and Conditions of Sale, and Product Warranty which are available on Vicor's webpage (<https://www.vicorpower.com/termsconditionswarranty>) or upon request.

Life Support Policy

VICOR'S PRODUCTS ARE NOT AUTHORIZED FOR USE AS CRITICAL COMPONENTS IN LIFE SUPPORT DEVICES OR SYSTEMS WITHOUT THE EXPRESS PRIOR WRITTEN APPROVAL OF THE CHIEF EXECUTIVE OFFICER AND GENERAL COUNSEL OF VICOR CORPORATION. As used herein, life support devices or systems are devices which (a) are intended for surgical implant into the body, or (b) support or sustain life and whose failure to perform when properly used in accordance with instructions for use provided in the labeling can be reasonably expected to result in a significant injury to the user. A critical component is any component in a life support device or system whose failure to perform can be reasonably expected to cause the failure of the life support device or system or to affect its safety or effectiveness. Per Vicor Terms and Conditions of Sale, the user of Vicor products and components in life support applications assumes all risks of such use and indemnifies Vicor against all liability and damages.

Intellectual Property Notice

Vicor and its subsidiaries own Intellectual Property (including issued U.S. and Foreign Patents and pending patent applications) relating to the products described in this data sheet. No license, whether express, implied, or arising by estoppel or otherwise, to any intellectual property rights is granted by this document. Interested parties should contact Vicor's Intellectual Property Department.

The products described on this data sheet are protected by U.S. Patents. Please see www.vicorpower.com/patents for the latest patent information.

Contact Us: <https://www.vicorpower.com/contact-us>

Vicor Corporation
25 Frontage Road
Andover, MA, USA 01810
Tel: 800-735-6200
Fax: 978-475-6715
www.vicorpower.com

email

Customer Service: custserv@vicorpower.com
Technical Support: apps@vicorpower.com

©2017 – 2023 Vicor Corporation. All rights reserved. The Vicor name is a registered trademark of Vicor Corporation.
All other trademarks, product names, logos and brands are property of their respective owners.